



Project Name:	
Location:	
Item:	Qty:
Model:	

BCF236-D / BCF30-D

CHEST FREEZERS



BCF236-D



BCF30-D

Berg split top hinged lid chest freezers are an excellent option for safely storing frozen food products such as meat, packaged foods, ice cream, vegetables, desserts and bags of ice while keeping them at the ideal storage temperature for extended life, maintaining quality and taste, preventing freezer burn and development of ice crystals. The stored product is easily accessible when it's time to use any of the contents. The included interior storage basket(s) helps you organize your products, so you can quickly locate and retrieve what you need. The refrigeration system is oversized so this unit can be used safely in a garage even if the temperature drops to 0°F or rises above 100°F. The hinged lid includes a lock and key to prevent unauthorized access to the contents. The freezer is sized to pull down its contents temperature level if loaded with pre-chilled products (recommended loading temperature for all products is $\leq 41^{\circ}\text{F}/5^{\circ}\text{C}$). The freezer design will provide years of reliable operation if properly maintained.

Berg's continuing commitment to quality products may mean a change in specification or pricing without notice.

FEATURES

- Sturdy hinged top opening lid that opens up to 90° makes access and servicing the freezer easy
- Includes lock to provide security even if unattended
- Utilizes CFC & HCFC free R-134A refrigerant
- Low profile casters for easy mobility
- Two (2) white wire storage baskets included for easy product organization

TEMPERATURE

- Holding temperature: 0° to 11°F (-24° to -18° C)
- Readily adjustable temperature set point (factory set at 5°F / -15°C)
- Rapid temperature recovery after opening lid
- Chest freezers hold frozen foods better than upright freezers as the cold air is retained in the storage compartment

CONSTRUCTION

- Exterior Material: White powder coated steel
- Interior Material: Aluminum
- Flat top-opening insulated double lid with integrated external handles
- 3" of environmentally friendly foam insulation
- Commercially approved oversized yet energy efficient refrigeration system meets 2017 DOE requirements
- Cold wall construction for even temperature profile in the chest freezer
- Manual defrost capability is provided to keep the walls frost-free and deliver the coldest possible contents
- Interior storage compartment is made from corrosion resistant materials



Specifications subject to change without notice.

Approvals: ANSI-UL 471 and ANSI-NSF-7 Approved. DOE 2017 Compliant

BCF236-D / BCF30-D



BCF236-D / BCF30-D

CHEST FREEZERS

BCF236-D

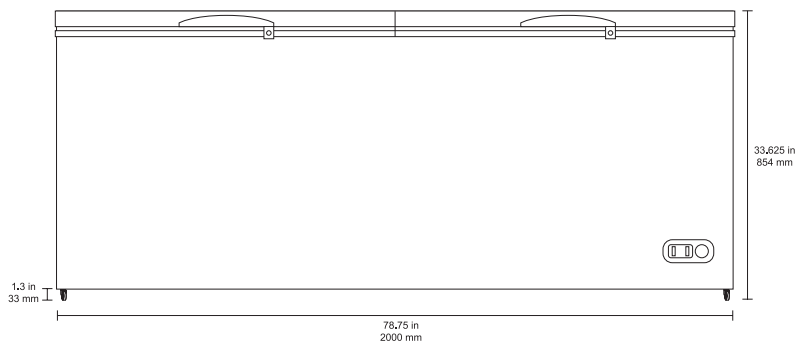

SIDE VIEW

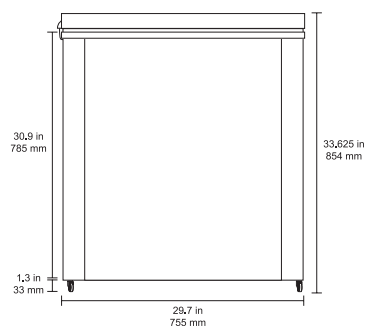

BCF30-D

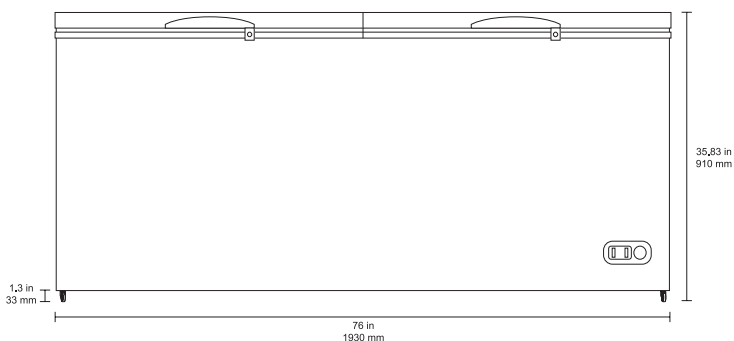

SIDE VIEW

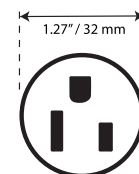
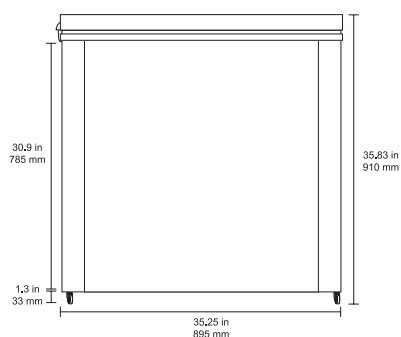

NEMA 5-15P

Comes with Nema 5-15 6' cord set as standard.
Requires a grounded circuit for safe operation.

	BCF236-D	BCF30-D
In: External Dimensions W x D X H	78.75 x 29.7 x 33.625	76 x 35.25 x 35.83
mm: External Dimensions W x D X H	2000 x 755 x 854	1930 x 895 x 910
Capacity	23.6 Cu Ft / 669 L	30 Cu Ft / 850 L
Manual Defrost	Yes	Yes
Voltage / Frequency	115V/60Hz	115V/60Hz
Average Amp Draw / Watts / HP	2.0 / 200 / 0.27	2.2 / 220 / 0.3
Temperature Range F°/C°	0° to 11° F -24° to -18° C	0° to 11° F -24° to -18° C
Factory Temperature Setting	5°F (-15°C)	5°F (-15°C)
Unit Weight	176 lb (80 kg)	209 lb (95 kg)
Shipping Weight	198.4 lb (90 kg)	242.5 lb (110 kg)