



Project Name:	
Location:	
Item:	Qty:
Model:	

BD750 / BD950

CHEST FREEZERS



BD750



BD950

Berg split top hinged lid chest freezers are an excellent option for safely storing frozen food products such as meat, packaged foods, ice cream, vegetables, desserts and bags of ice while keeping them at the ideal storage temperature for extended life, maintaining quality and taste, preventing freezer burn and development of ice crystals. The stored product is easily accessible when it's time to use any of the contents. The included interior storage basket(s) helps you organize your products, so you can quickly locate and retrieve what you need. The refrigeration system is oversized so this unit can be used safely in a garage even if the temperature drops to 0°F or rises above 90°F. The hinged lid includes a lock and key to prevent unauthorized access to the contents. The freezer is sized to pull down its contents temperature level if loaded with pre-chilled products (recommended loading temperature for all products is ≤41°F/5°C). The freezer design will provide years of reliable operation if properly maintained.

Berg's continuing commitment to quality products may mean a change in specification or pricing without notice.

FEATURES

- Sturdy hinged top opening lid that opens up to 90° makes access and servicing the freezer easy
- Includes lock to provide security even if unattended
- Utilizes CFC & HCFC free R-134A refrigerant
- Low profile casters for easy mobility
- Two (2) white wire storage baskets included for easy product organization

TEMPERATURE

- Holding temperature: -10° to 10°F (-23° to -12° C)
- Readily adjustable temperature set point (factory set at 0°F / -17.8°C)
- Rapid temperature recovery after opening lid
- Chest freezers hold frozen foods better than upright freezers as the cold air is retained in the storage compartment

CONSTRUCTION

- Exterior Material: White powder coated steel
- Interior Material: Aluminum
- Flat top-opening insulated double lid with integrated external handles
- 3" of environmentally friendly foam insulation
- Commercially approved oversized yet energy efficient refrigeration system meets 2020 DOE requirements
- Cold wall construction for even temperature profile in the chest freezer
- Manual defrost capability is provided to keep the walls frost-free and deliver the coldest possible contents
- Interior storage compartment is made from corrosion resistant materials



Specifications subject to change without notice.

Approvals: ANSI-UL 471 and ANSI-NSF-7 Approved. DOE 2020 Compliant

BD750 / BD950



BD750 / BD950

CHEST FREEZERS

BD750

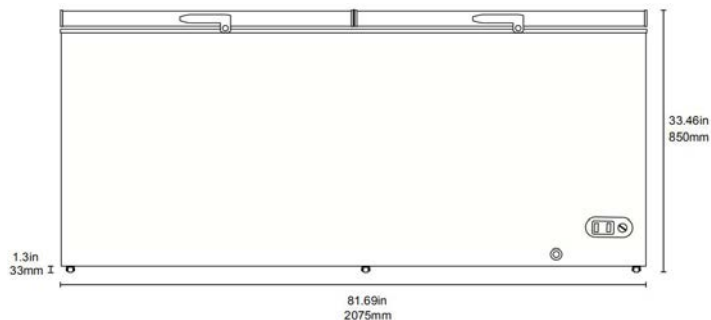

SIDE VIEW

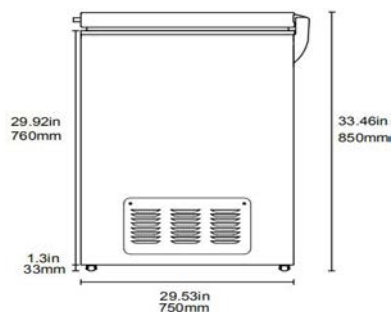

BD950

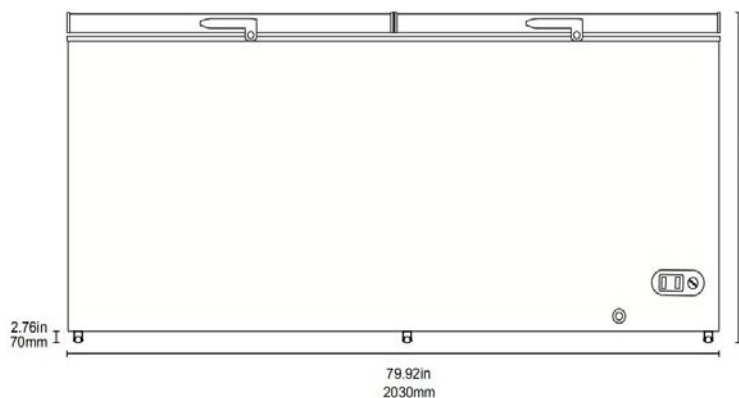

SIDE VIEW

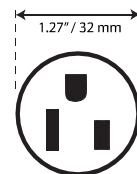
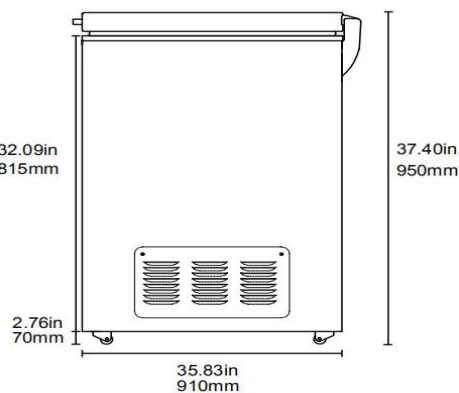

NEMA 5-15P

Comes with Nema 5-15 6' cord set as standard.
Requires a grounded circuit for safe operation.

	BD750	BD950
In: External Dimensions W x D X H	81.69 x 29.53 x 33.46	79.92 x 35.83 x 37.40
mm: External Dimensions W x D X H	2075 x 750 x 850	2030 x 910 x 950
Capacity	23.7 Cu Ft / 670 L	30.6 Cu Ft / 867 L
Manual Defrost	Yes	Yes
Voltage / Frequency	115V/60Hz	115V/60Hz
HP	0.21	0.26
Temperature Range F°/C°	-10° to 10° F -23° to -12° C	-10° to 10° F -23° to -12° C
Factory Temperature Setting	0°F (-17.8°C)	0°F (-17.8°C)
Unit Weight	166.4 lbs (75.5 kg)	194 lbs (88 kg)
Shipping Weight	183.0 lbs (83 kg)	254 lbs (115 kg)