



Project Name:	
Location:	
Item:	Qty:
Model:	

STH23BRG STH49BRG GLASS DOOR REACH-IN REFRIGERATORS



CONSTRUCTION

- Exterior is constructed of 430 stainless steel
- Interior is constructed of 304 stainless steel
- The cabinet is insulated throughout with a foamed-in-place high density cell polyurethane insulation
- Positive self-closing glass doors

TEMPERATURE

- Refrigeration units use environmentally friendly R290 refrigerant
- Electric LED temperature controller provides a digital display of cabinet temperatures and allows for easy temperature adjustments when necessary
- Maintains a temperature range of 33°– 41°F
- Rugged built evaporator fans run efficiently with low velocity and high volume air flow

FEATURES

- Includes 4” casters
- Bright LED lighting for enhanced product visibility
- Removable door gasket for easy cleaning
- Adjustable plastic coated steel shelves
- Locking door(s) keep items inside secure after hours

WARRANTY

- Two year parts and labor
- Five years on the compressor

These units comes with a NEMA 5-15 seven foot cord. Requires a grounded circuit for safe operation.

BERG Glass Door Reach-in Refrigerators are constructed of heavy duty stainless steel both inside and out, making them strong and durable enough to survive any kitchen environment.

All models comewith 4”casters and plastic coated wire shelving that is easily removable to adjust the shelf height. The front digital controllers and LED readout makes it easy to adjust the interior temperature.

These models are ETL Listed and ETL Sanitation.

They are backed with a 2 year warranty on parts and labor a 5 year warranty on the compressor.

STH23BRG STH49BRG

	<p>Specifications subject to change without notice.</p> <p>For warranty service on these products, please call BERG at 888-585-9440</p>
--	---



Project Name:	
Location:	
Item:	Qty:
Model:	

STH23BRG STH49BRG

GLASS DOOR REACH-IN REFRIGERATORS

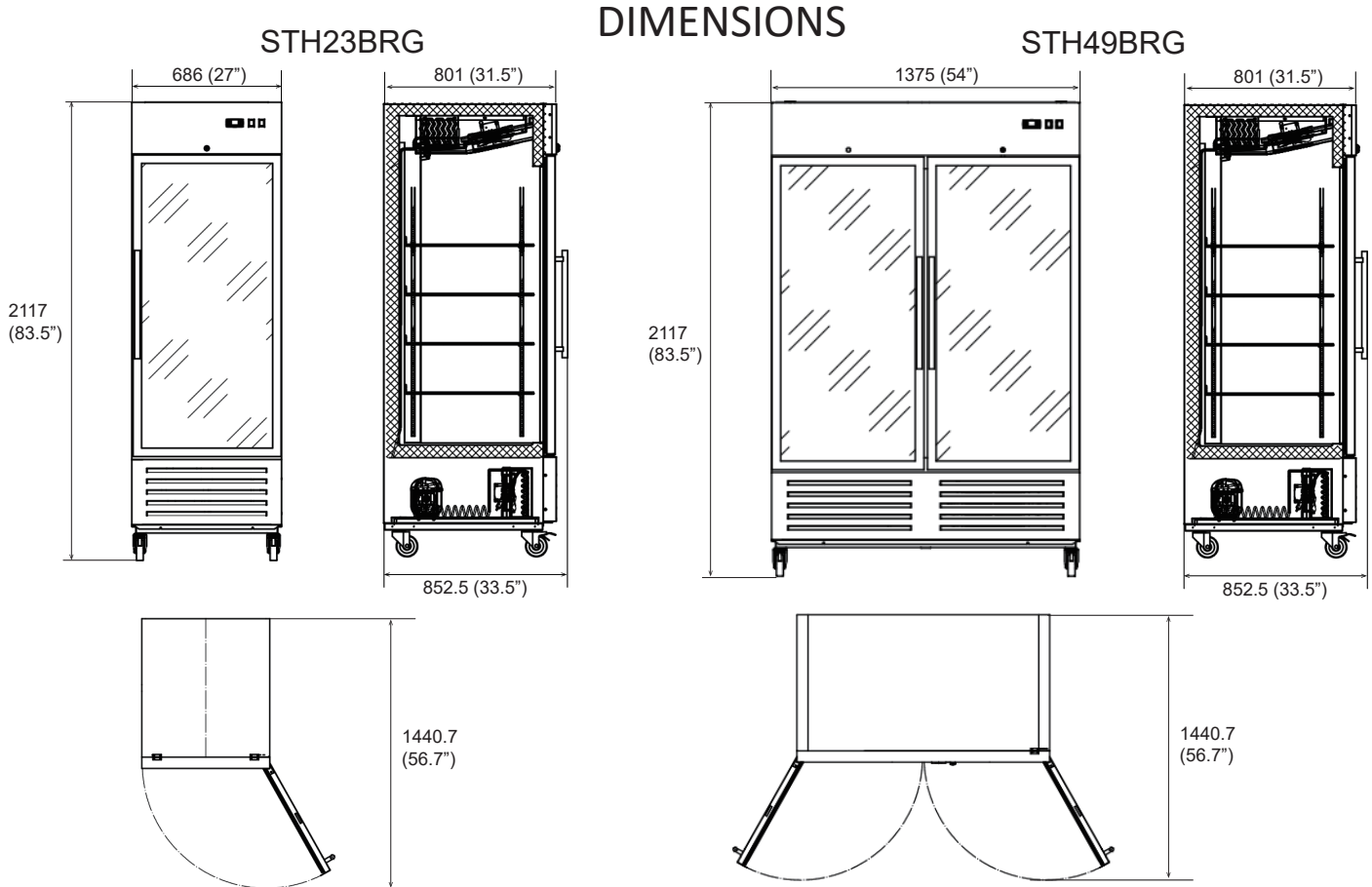

Model Number	STH23BRG	STH49BRG
Doors	1	2
Shelves	4	8
Net Volume (Cu. Ft)	21	46
Overall Dimensions (in)	27 x 33.5 x 83.5	54.1 x 33.5 x 83.5
Interior Dimensions (in)	22.2 x 26.8 x 60.4	49.4 x 26.8 x 60.4
Horsepower	1/4	3/8
Refrigerant	R290	R290
Voltage/Hertz/Phase	115/60/1	115/60/1
Amps	2.6	4
Net Weight (lbs)	267	412
Gross Weight (lbs)	346	520
Shipping Dimensions (in)	30 x 35.4 x 85.1	56.3 x 35.4 x 85.1

STH23BRG STH49BRG