



Berg Deli Cases are great for merchandising and storing all of your most popular deli meats and cheeses. It's curved glass front provides your customers with excellent product visibility while the rounded corner design makes for easy cleaning. Their high humidity gravity coil refrigeration system helps to maintain the optimal storing temperature to keep all of your displayed meats and cheese products fresh for extended periods of time. These items come standard with adjustable epoxy coated steel shelves and LED lighting for enhanced product visibility. These models are ETL Listed and ETL Sanitation and backed by a 1 year warranty on parts and labor and a 5 year warranty on the compressor.

Product Features

- Exterior is constructed with a stainless steel top and black coated steel sides, back and front
- Interior has a painted aluminum liner and 304 stainless steel floor
- High humidity gravity coil refrigeration system for optimal product freshness
- R-290 refrigerant ensures ideal operating temperatures
- Damage-resistant curved front glass
- Foamed-in-place polyurethane high density cell insulation throughout the entire cabinet
- Adjustable epoxy coated steel shelves
- LED lighting for enhanced product visibility



Specifications



Model Number	BSDC-36	BSDC-48	BSDC-64	BSDC-82
Rear Doors	2	2	3	3
Shelves	4	6	9	9
Net Volume (Cu. Ft.)	11.6 Cu. Ft.	15.5 Cu. Ft.	21.9 Cu. Ft.	30.9 Cu. Ft.
Overall Dimensions (in) wxdxh	36" x 32.5" x 43"	47.25" x 32.5" x 43"	64" x 32.5" x 43"	82" x 32.5" x 43"
Interior Dimensions (in) wxdxh	32.25" x 26.75" x 26.75"	43.25" x 26.75" x 26.75"	60.25" x 26.75" x 26.75"	78" x 26.75" x 26.75"
Refrigerant	R-290	R-290	R-290	R-290
Horsepower	1/3	1/4	3/5	3/4
Voltage/Hertz/Phase	115/60/1	115/60/1	115/60/1	115/60/1
Amps/Watts	4.68A/368W	3.12A/320W	7.14A/580W	7.08A/658W
Net Weight (lbs)	260 lbs	319 lbs	399 lbs	507 lbs
Gross Weight (lbs)	297 lbs	388 lbs	485 lbs	601 lbs
Shipping Dimensions (in) wxdxh	40" x 36.25" x 48.75"	51" x 36.25" x 48.75"	68" x 36.25" x 48.75"	86" x 36.25" x 48.75"

Plan Views

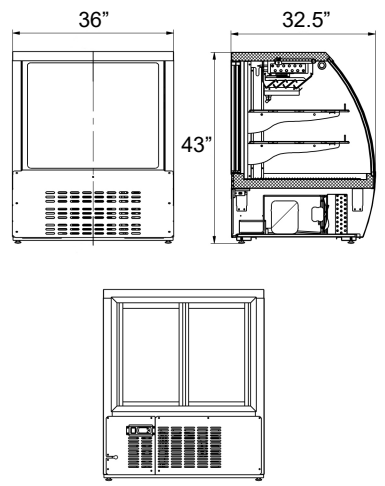

BSDC-36

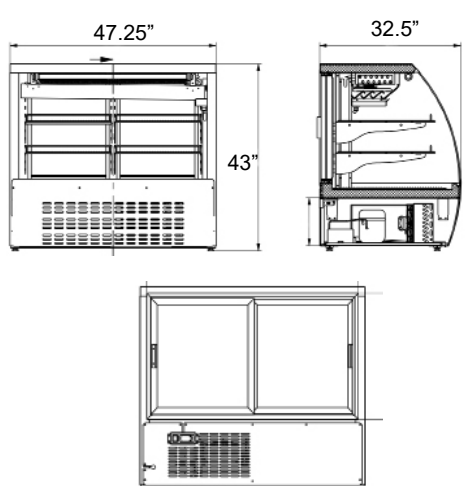

BSDC-48

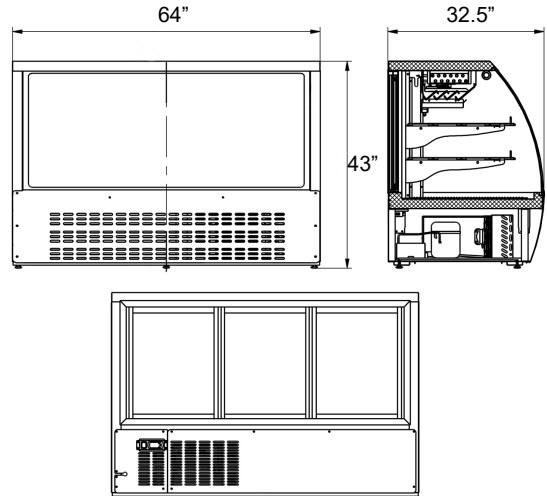

BSDC-64

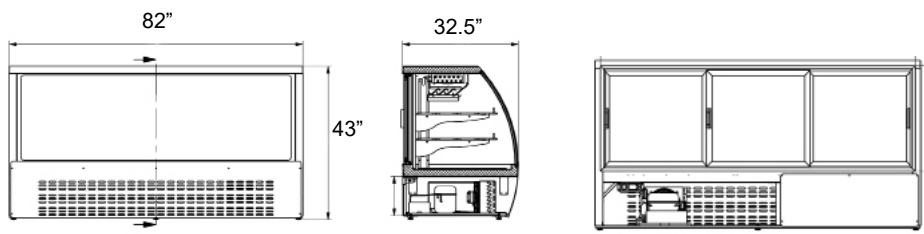

BSDC-82

Features

Cooling System

- Refrigeration units use environmentally friendly R-290 refrigerant
- Digital temperature controls maintain a temperature range of 33°F–41°F
- High humidity gravity coil system is ideal for keeping deli meats and cheeses fresh
- Condensing unit is rear mounted and slides out for easy cleaning
- Automatic defrost system

Electrical Control

- 115V/60 connection for all models
- 8' power cord with NEMA 5-15 plug from the back of the unit



Cabinet Construction

- Exterior is constructed with a stainless steel 21" deep worktop and black coated steel sides, back and front
- Interior is constructed with a 304 type stainless steel floor and painted aluminum sides
- The cabinet is insulated throughout with a foamed-in-place high density cell polyurethane insulation
- Adjustable leg levelers attached to the frame

Rear Doors

- Rear doors slide open for easy access to the products inside

Curved Front Glass

- Damage-resistant curved front glass provides excellent product visibility for merchandising

Shelving

- Heavy duty epoxy coated steel shelves are adjustable and can hold up to 90 lbs each
- Shelving system has adjustable angle settings

Model Features

- Interior LED lighting for enhanced product visibility
- 21" deep stainless steel worktop

Operating Conditions

- These models are designed to operate in an environment where the temperature and humidity do not exceed 75°F and 55% relative humidity
- These deli cases are only intended to be used for meats, cheeses and salads.
- These cases are not intended to hold or display pies, cakes or other pastries.